

Mobile Home Posts / Pedestal Accessories

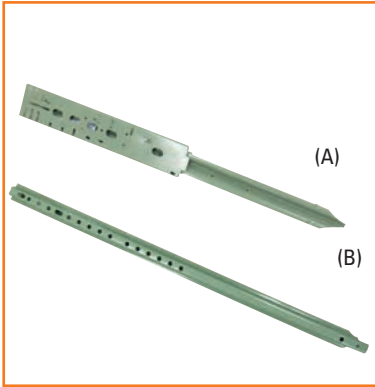

Posts and Stakes

Mobile Home Posts and Mounting Stakes

Mounting posts are designed for mounting station protection blocks and network interface devices (NIDs) in applications where they cannot be wall mounted including businesses and mobile home communities. These posts are constructed of heavy gauge steel. Screws are provided.

PREMIER[®]

Item No.	Mfg. Part No.	Description
(A)	0000406590	PT – MH Post 36 - 48
(B)	0000406591	PT- Pedestal Stake 42

House Risers



House Risers

- RUS approved
- Lightweight gray PVC
- Clamps included

PREMIER[®]

Item No.	Mfg. Part No.	Description	Height (Feet)	Clamp Packaging	Product Packaging pcs/ctn	I.D. (Inches)	O.D. (Inches)
7231997500	HR-78-5-Offset	PREMIER Riser, 7/8" OD x 5' in Length, 7/8" Offset at One End, Straight at Other End With Notch on Both Ends	5	2 clamps attached to risers with tape	60	0.696	0.84
7236097500	HR-125-5-LARGE	PREMIER Riser, 1 1/4" OD x 5' in Length, 7/8" Offset One End, with Notch at Both Ends	5	2 clamps attached to risers w/tape	60	1.106	1.25
7231827500	HR-78-5-L-Bend	PREMIER Riser, 7/8" OD x 5' in Length, with 7/8" Offset & Notch at One End and a 90° L-bend with 18" Long Leg without Notch at Other End	5	2 clamps attached to risers with tape	60	0.696	0.84
7233067500	HR-78-CLAMP	Clamp to Fit 7/8" PREMIER Riser	N/A	Bulk	100		
7235717500	HR-125-CLAMP	Clamp to Fit 1 1/4" PREMIER Riser	N/A	Bulk	100		